



# SPARE PARTS LIST

BLOWERS

360 BT

**A** 360BT  
TUBES

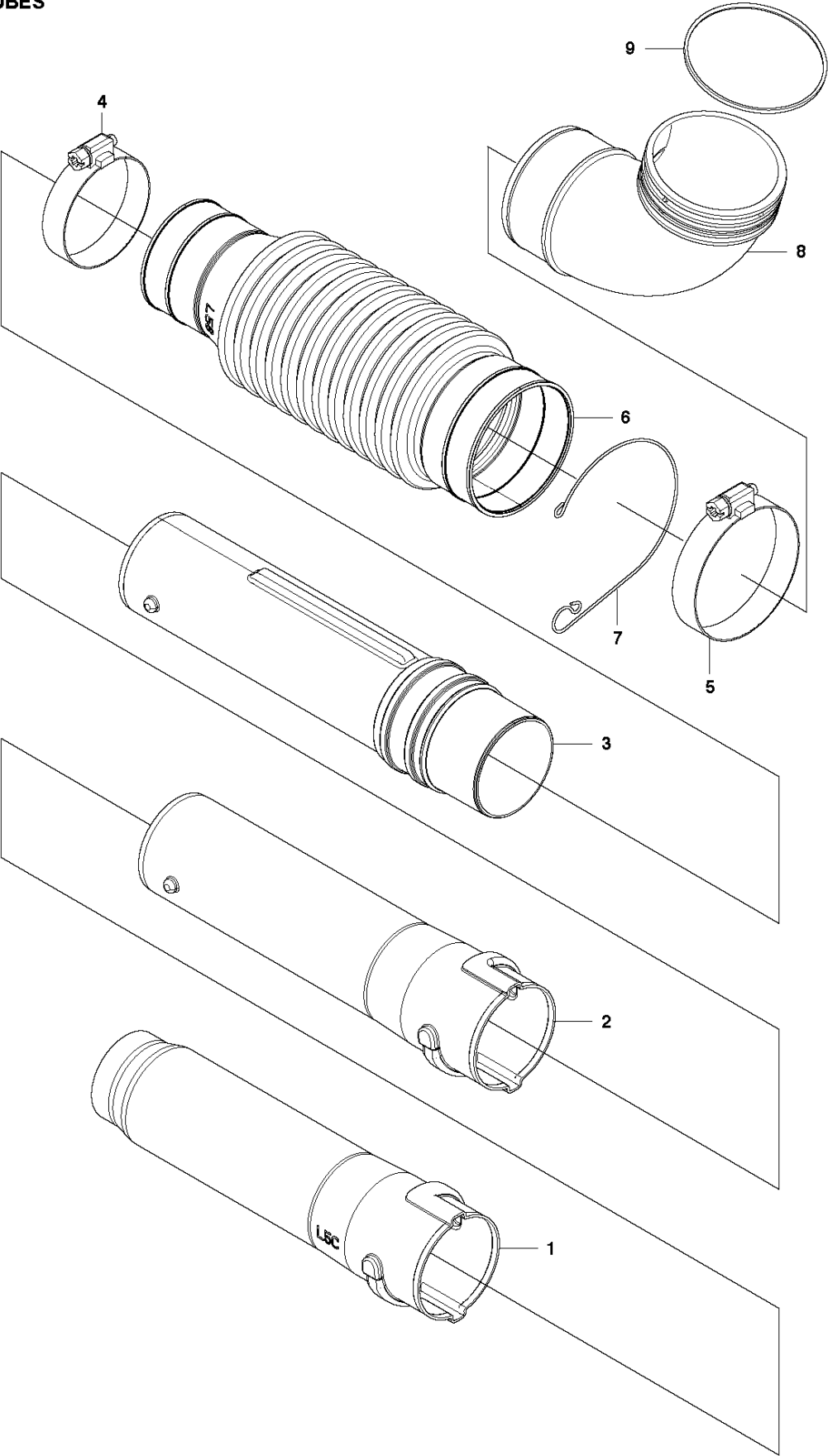

Ref	Part No	Description	Remark	QTY KIT
1	577 31 32-01	PIPE		1
2	577 31 30-01	PIPE		1
3	577 31 76-01	JOINT		1
4	544 27 40-01	CLAMP		1
5	544 27 41-01	CLAMP		1
6	505 18 09-01	HOSE		1
7	502 84 28-01	CLAMP		1
8	576 57 83-01	ELBOW		1
9	581 29 08-01	O-RING		1

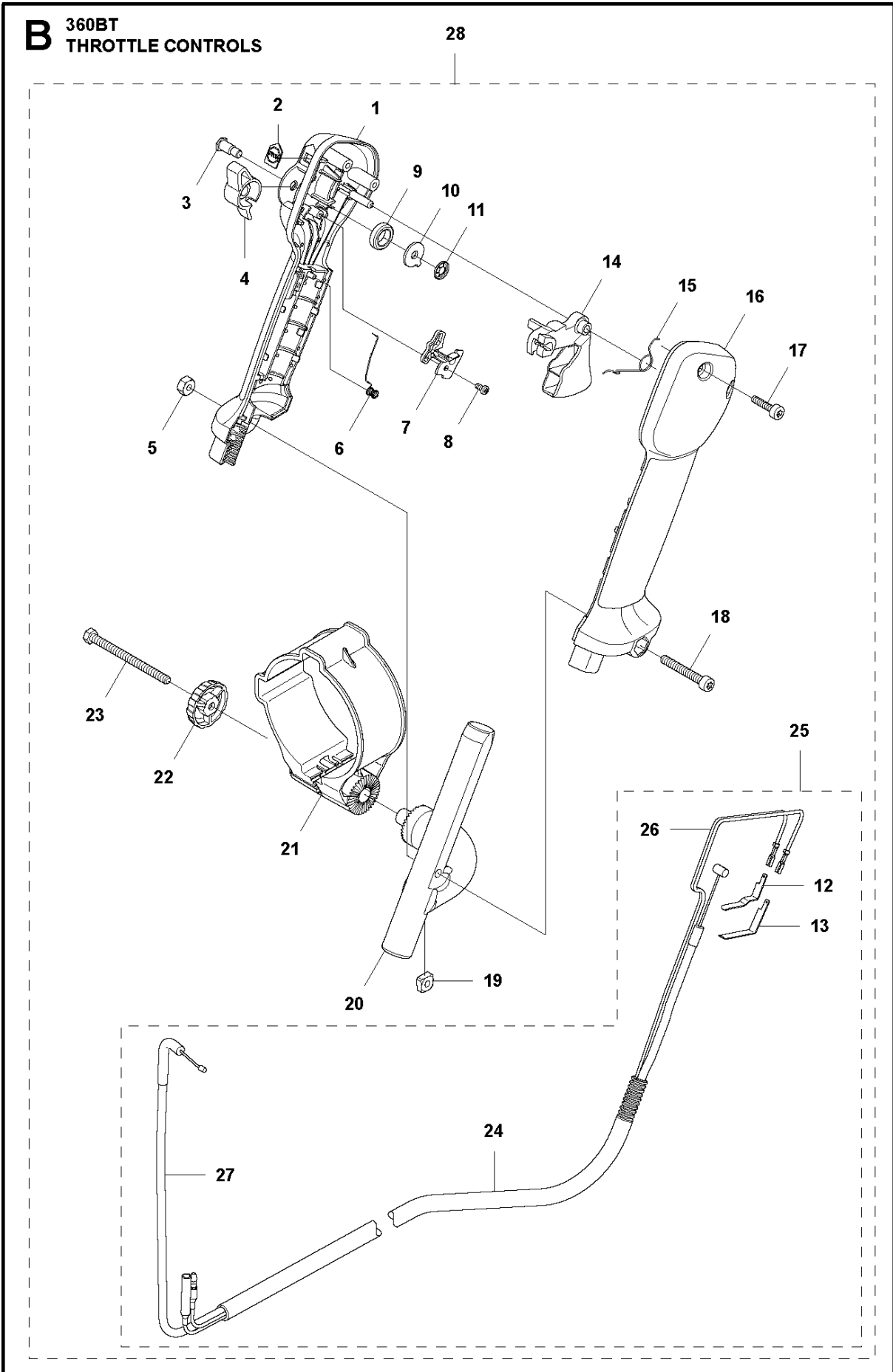

## THROTTLE CONTROLS

360 BT

Ref	Part No	Description	Remark	QTY	KIT
1	502 24 48-01	HANDLE HALF		1	28
2	502 64 17-01	PLATE		1	28
3	537 14 12-03	SHAFT PIVOT		1	28
4	502 24 55-01	CONTROL		1	28
5	510 91 12-01	NUT		1	28
6	505 56 79-01	SPRING		1	28
7	502 24 60-01	RETAINER		1	28
8	505 29 10-01	SCREW		1	28
9	537 37 39-01	SPRING		1	28
10	505 18 15-01	WASHER		1	28
11	735 58 35-01	WASHER		1	28
12	537 22 63-01	CONNECTOR		1	25, 28
13	537 22 62-01	CONNECTOR		1	25, 28
14	502 24 54-01	TRIGGER		1	28
15	537 17 42-01	SPRING THROTTLE TRIG		1	28
16	502 24 49-01	HANDLE HALF		1	28
17	505 29 12-01	SCREW		2	28
18	505 29 08-01	SCREW		1	28
19	503 22 65-01	SQUARE NUT		1	28
20	502 24 53-01	HOLDER		1	28
21	577 31 77-01	HANDLE HOLDER		1	28
22	504 80 03-01	TURNING KNOB		1	28
23	725 23 44-51	SCREW EHHM		1	28
24	577 75 69-01	TUBE		1	25, 28
25	576 78 56-01	WIRING ASSY		1	28
26	576 78 57-01	CORD		1	25, 28
27	576 78 58-01	CABLE		1	25, 28
28	577 26 14-01	LEVER ASSY		1	

**C** 360BT  
CYLINDER COVER

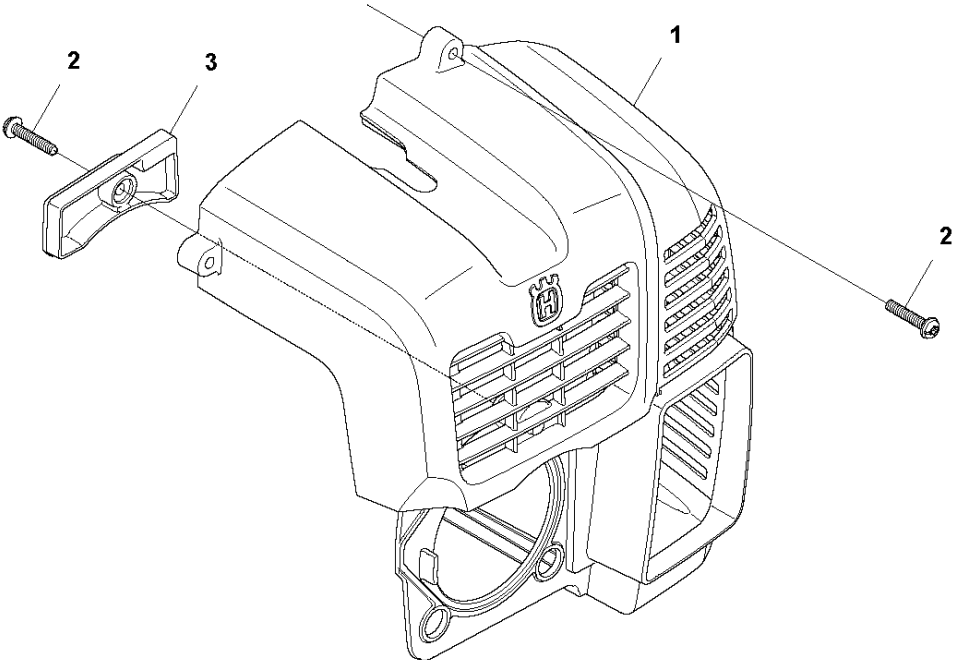

CYLINDER COVER

360 BT

Ref	Part No	Description	Remark	QTY KIT
1	576 57 85-01	ENGINE COVER		1
2	512 84 81-01	SCREW		5
3	576 57 86-01	COVER		1

**D** 360BT  
STARTER

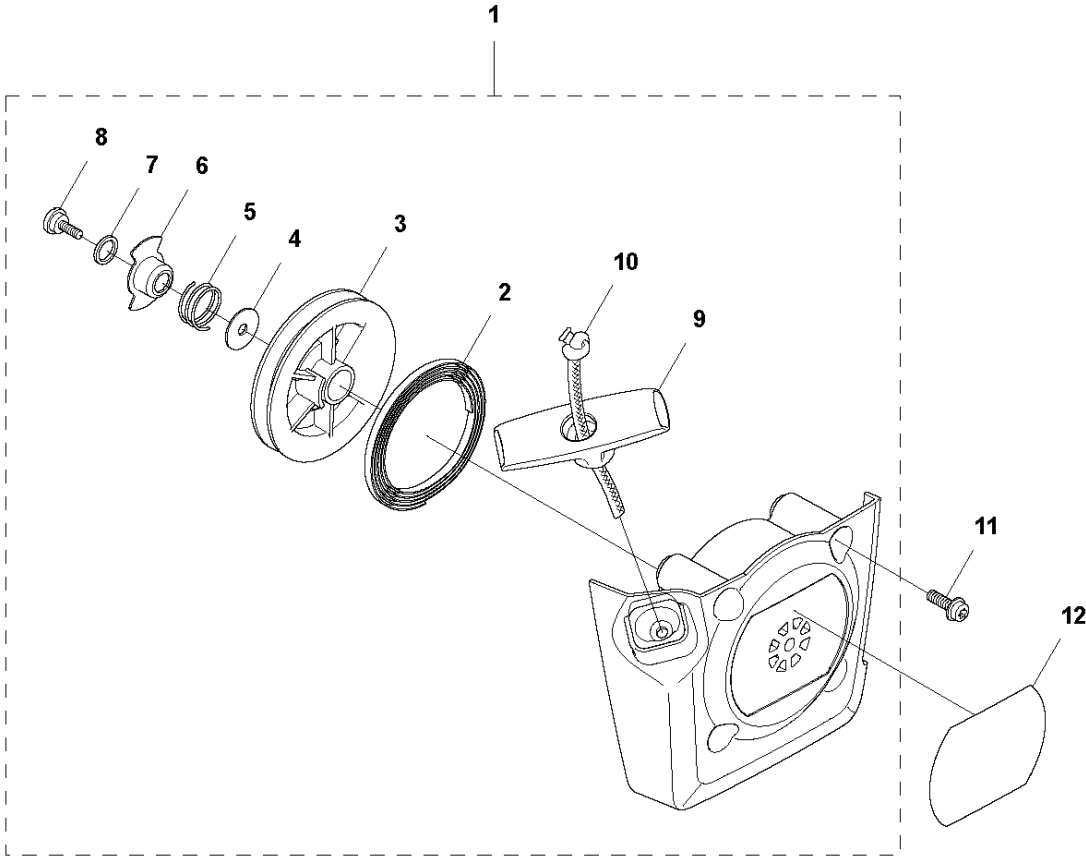



## STARTER

360 BT

Ref	Part No	Description	Remark	QTY	KIT
1	578 28 35-01	STARTER ASSY		1	
2	521 62 96-01	SPRING		1	1
3	576 59 42-01	REEL		1	1
4	521 63 08-01	WASHER		1	1
5	521 63 06-01	SPRING		1	1
6	521 63 03-01	PLATE		1	1
7	521 63 12-01	WASHER		1	1
8	515 36 71-01	SCREW		1	1
9	537 23 25-01	STARTER HANDLE		1	1
10	577 05 31-01	ROPE		1	1
11	506 74 56-01	BOLT		4	
12	580 89 90-01	DECAL		1	

**E** 360BT  
CARBURETOR & AIR FILTER

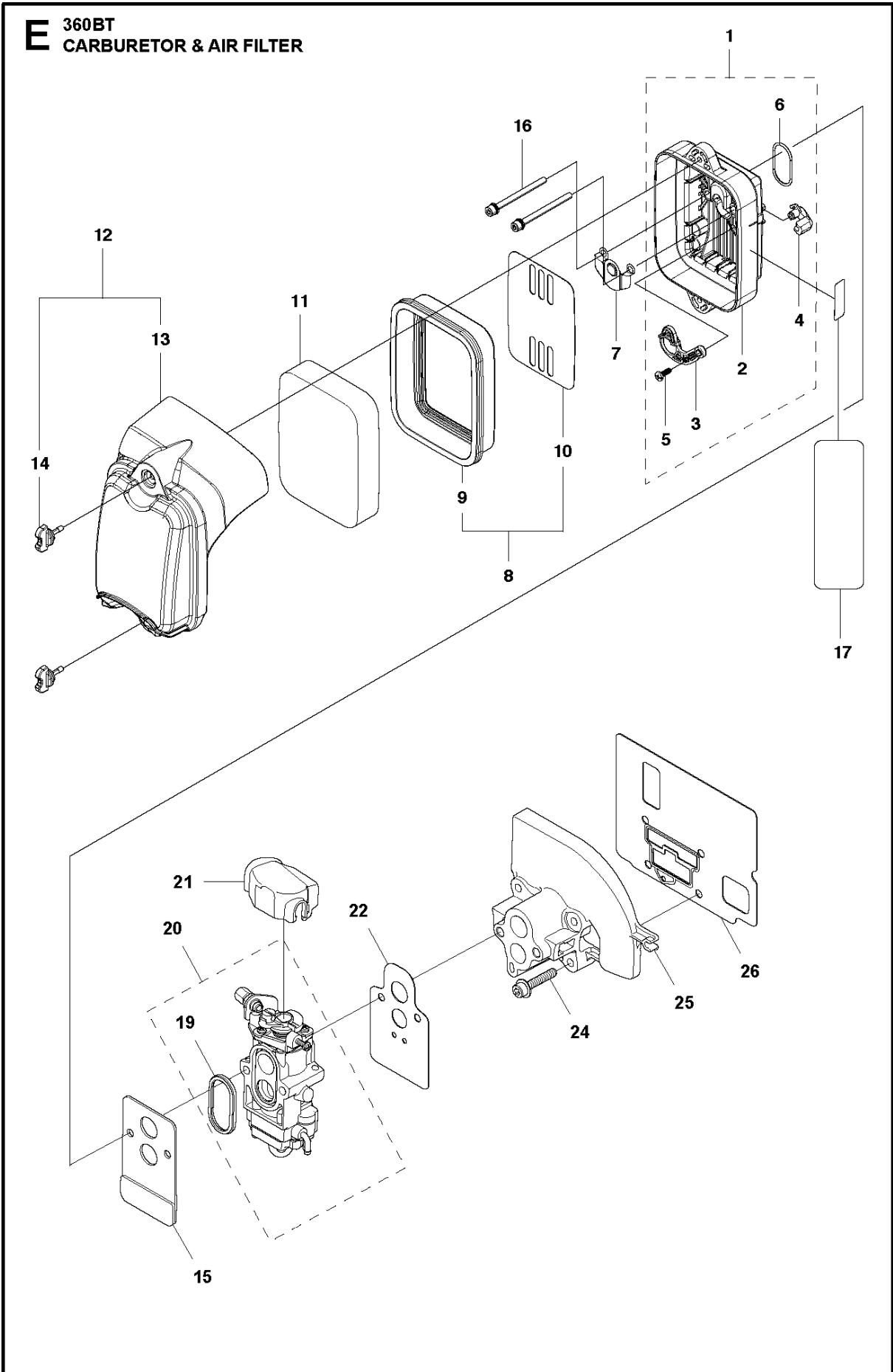

## CARBURETOR &amp; AIR FILTER

360 BT

Ref	Part No	Description	Remark	QTY	KIT
1	502 84 49-02	AIR FILTER HOLDER		1	
2	577 96 15-01	AIR FILTER HOLDER		1	1
3	512 25 96-01	PLATE.CHOKE		1	1
4	521 74 05-01	LEVER		1	1
5	581 73 62-01	SCREW		1	1
6	512 26 00-01	O-RING		1	1
7	502 84 47-01	PLATE		1	
8	502 84 45-01	GASKET		1	
9	512 26 03-01	PACKING		1	8
10	512 26 04-01	SCREEN		1	8
11	502 84 44-02	AIR FILTER		1	
12	577 18 14-01	AIR FILTER COVER		1	
13	577 03 01-01	AIR FILTER COVER		1	12
14	502 84 43-01	KNOB		2	12
15	578 27 40-01	PLATE		1	
16	502 84 46-01	SCREW		2	
17	521 74 02-01	LABEL		1	
19	521 63 15-01	RING		1	20
20	581 15 58-01	CARBURETTOR		1	
21	506 74 42-01	COVER		1	
22	577 08 96-01	GASKET		1	
24	576 58 98-01	BOLT		1	
25	578 10 84-01	INSULATOR		1	
26	577 69 48-01	GASKET		1	

**F** 360BT  
MUFFLER

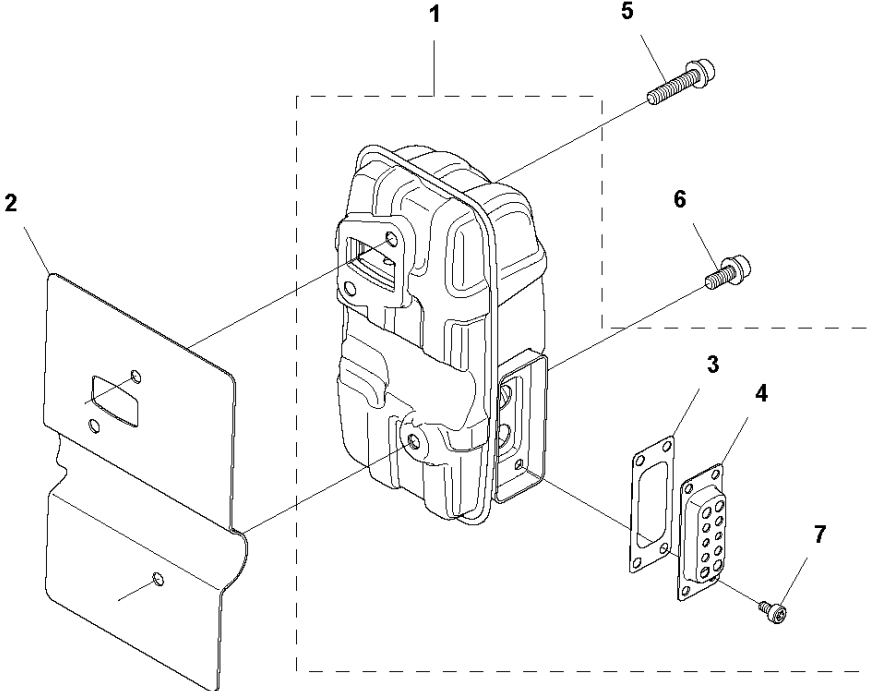

MUFFLER

360 BT

Ref	Part No	Description	Remark	QTY	KIT
1	585 04 42-01	MUFFLER ASSY		1	
2	576 59 09-01	GASKET		1	
3	585 04 44-01	SPARK ARRESTER		1	1
4	585 04 45-01	DIFFUSER		1	1
5	576 59 07-01	BOLT		2	
6	576 59 08-01	BOLT		1	
7	544 36 27-01	BOLT		4	1

**G** 360BT  
FUEL TANK

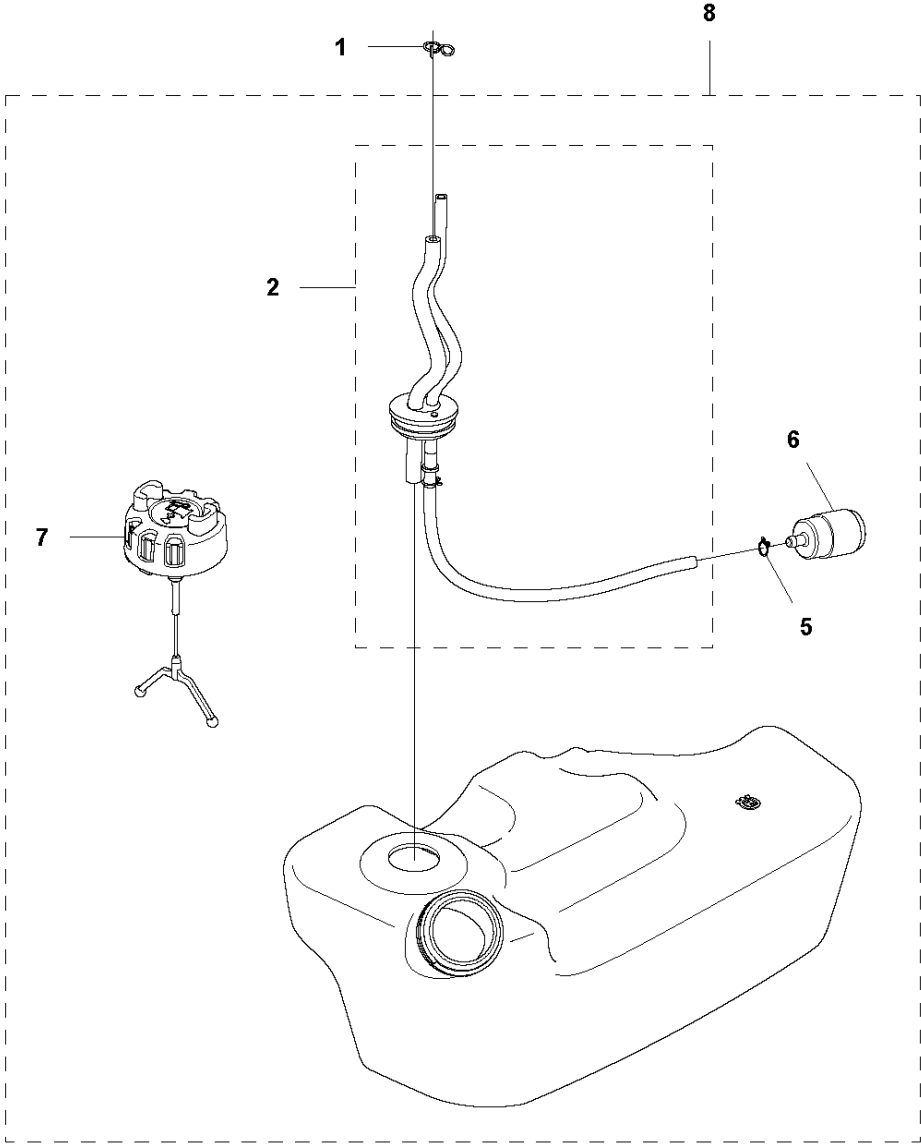

FUEL TANK

360 BT

Ref	Part No	Description	Remark	QTY	KIT
1	506 74 15-01	CLIP		1	
2	586 35 96-04	HOSE ASSY		1	8
5	506 70 70-01	CLIP		1	8
6	506 74 26-01	FILTER		1	8
7	504 03 18-01	TANK CAP ASSY		1	8
8	577 46 78-01	FUEL TANK	For all except USA and Canada	1	
8	579 14 05-01	TANK ASSY	For USA and Canada	1	

**H** 360BT  
IGNITION SYSTEM

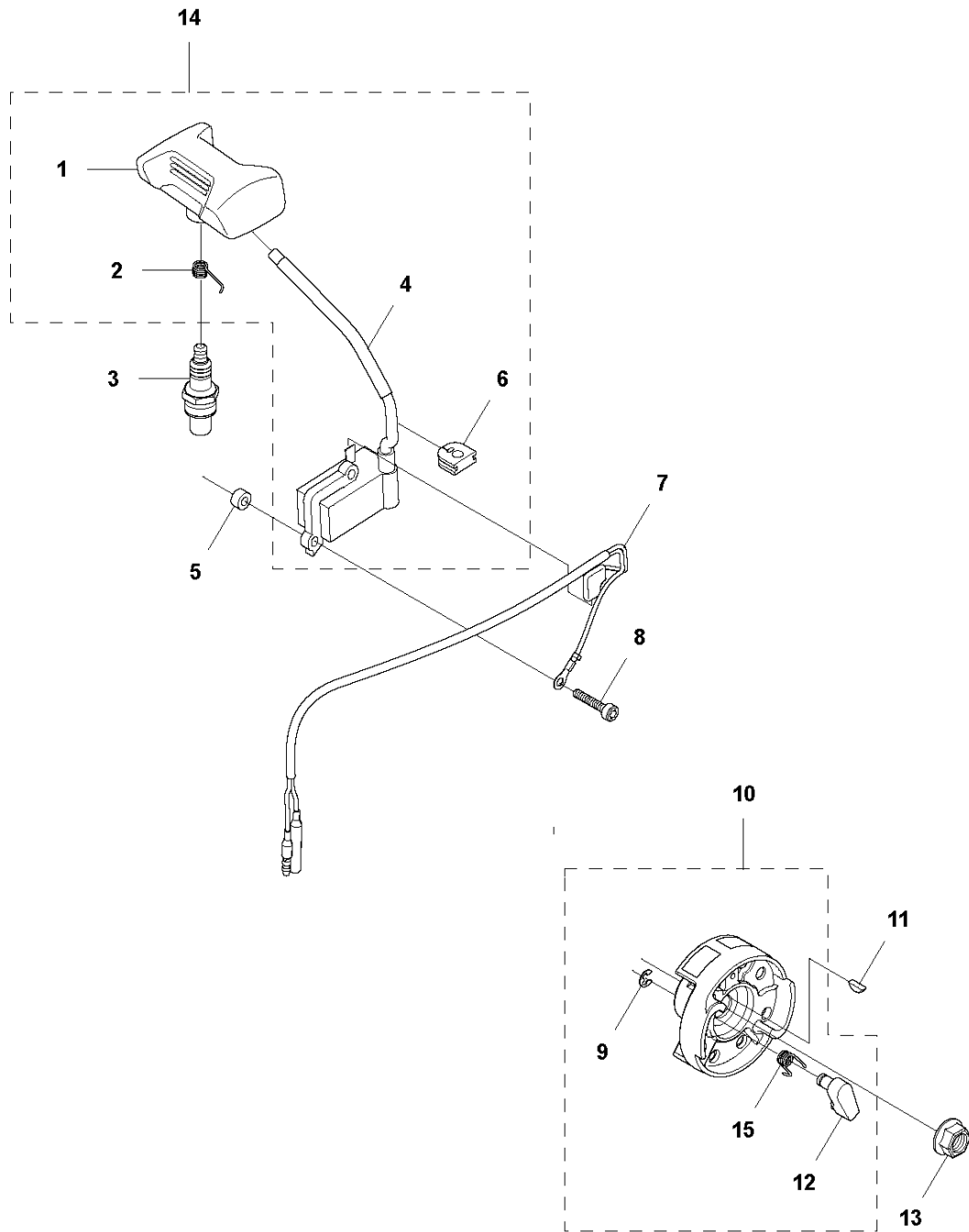



## IGNITION SYSTEM

360 BT

Ref	Part No	Description	Remark	QTY	KIT
1	587 98 47-01	SPARK PLUG CAP		1	14
2	506 65 52-01	SPRING		1	14
3	521 23 34-01	SPARK PLUG		1	
4	587 65 44-01	TUBE		1	14
5	588 17 14-01	SPACER		2	
6	515 41 53-01	GROMMET		1	14
7	576 59 38-01	CORD		1	
8	579 38 30-01	BOLT		2	
9	510 49 01-01	RING		2	10
10	587 65 51-01	ROTOR		1	
11	506 68 94-01	KEY		1	
12	587 65 50-01	RATCHET		2	10
13	513 24 19-01	NUT		1	
14	587 98 45-01	COIL		1	
15	587 65 49-01	SPRING		2	10

**J** 360BT  
CYLINDER & PISTON

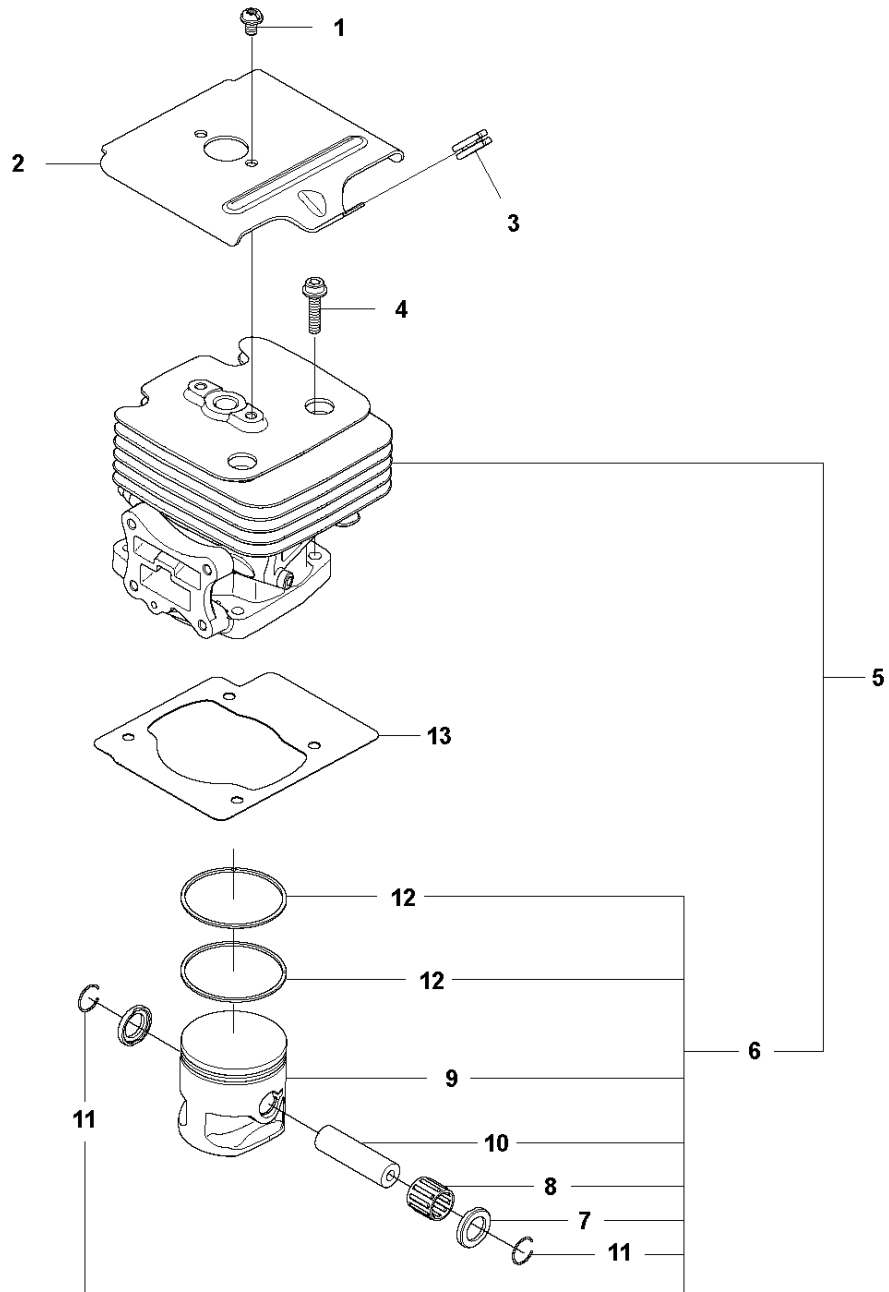

## CYLINDER PISTON

360 BT

Ref	Part No	Description	Remark	QTY	KIT
1	544 25 68-01	SCREW		2	
2	576 58 95-01	PLATE		1	
3	576 58 96-01	GROMMET		1	
4	506 74 52-01	BOLT		4	
5	578 38 49-01	CYLINDER		1	
6	529 09 47-01	PISTON-G		1	5
7	521 52 05-01	WASHER		2	5, 6
8	576 69 64-01	BEARING		1	5, 6
9	544 25 92-01	PISTON		1	5, 6
10	544 25 94-01	PISTON PIN		1	5, 6
11	521 53 19-01	SNAP RING		2	5, 6
12	544 25 93-01	PISTON RING		2	5, 6
13	576 58 94-01	GASKET		1	

**K** 360BT  
CRANK CASE

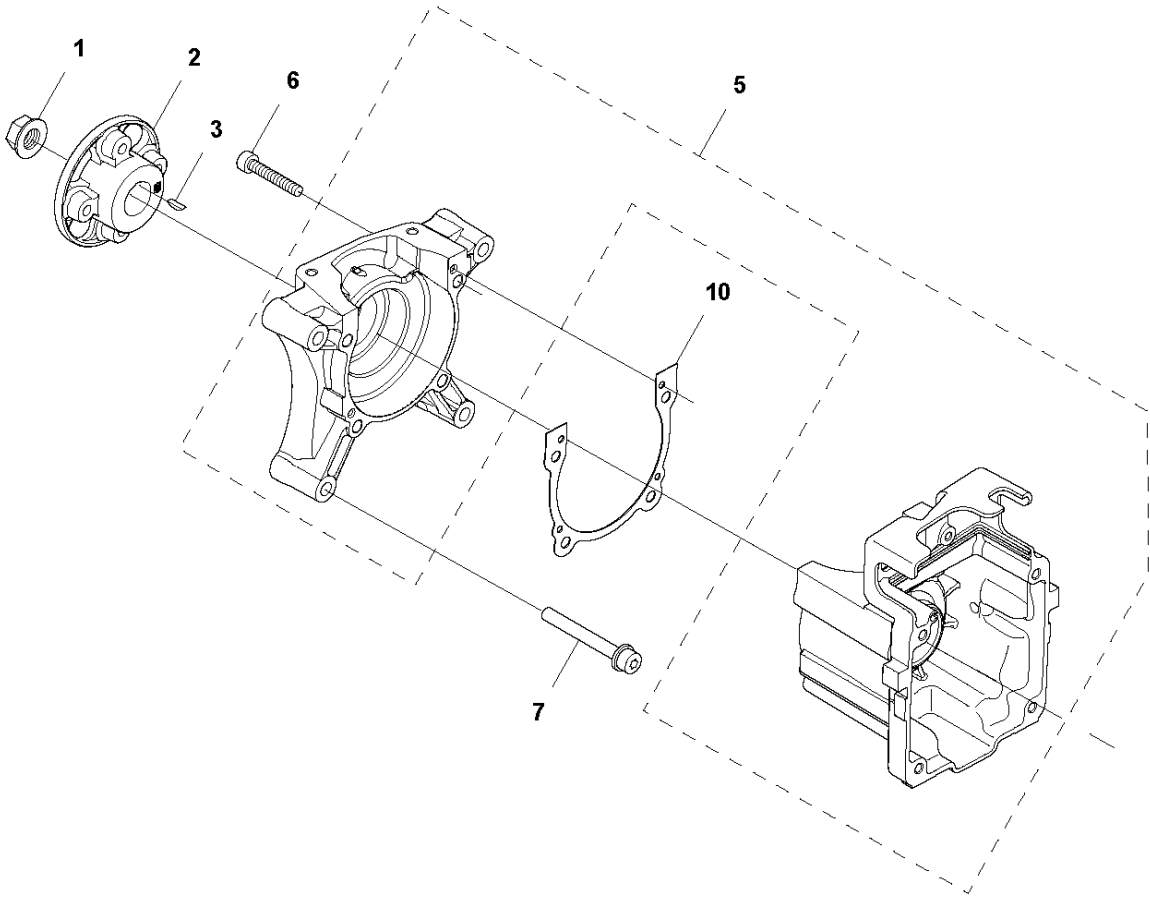

CRANKCASE

360 BT

Ref	Part No	Description	Remark	QTY KIT
1	513 24 19-01	NUT		1
2	577 14 43-01	COUPLING		1
3	506 68 94-01	KEY		1
5	577 06 74-01	CRANKCASE		1
6	515 38 81-01	BOLT		4
7	576 56 43-01	BOLT		4
10	576 59 16-01	GASKET		1

**L** 360BT  
CRANK SHAFT

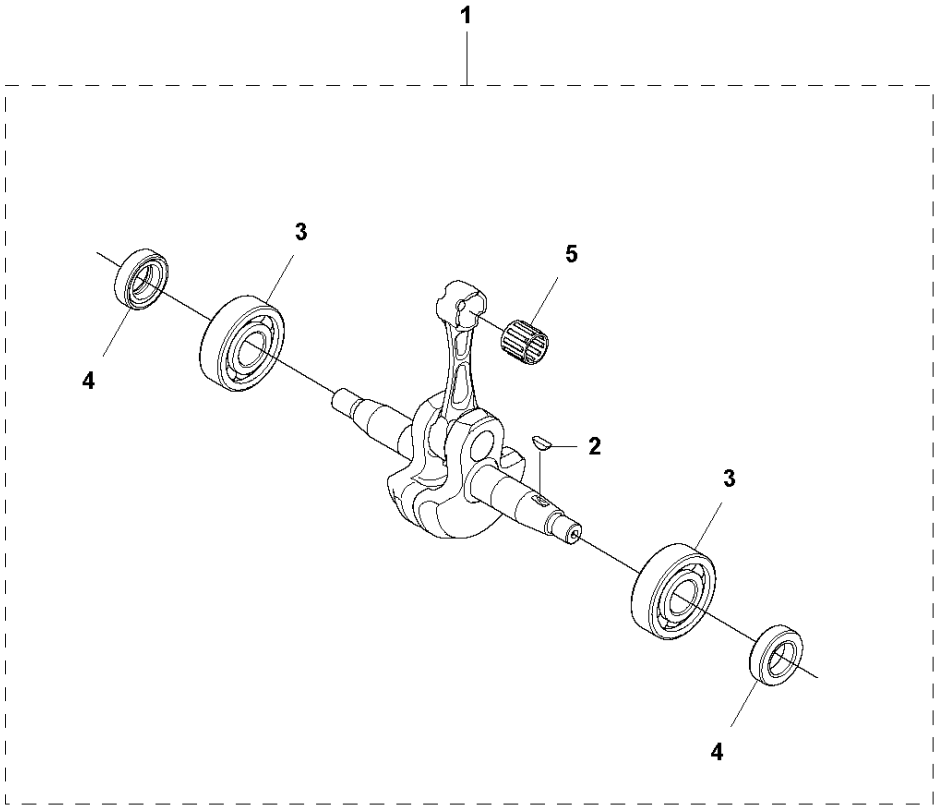

CRANKSHAFT

360 BT

Ref	Part No	Description	Remark	QTY KIT
1	578 38 51-02	SERVICE KIT		1
2	506 68 94-01	KEY		1
3	521 52 13-01	BEARING		2
4	521 52 19-01	SEAL		2
5	576 69 64-01	BEARING		1

**M** 360BT  
FAN HOUSING

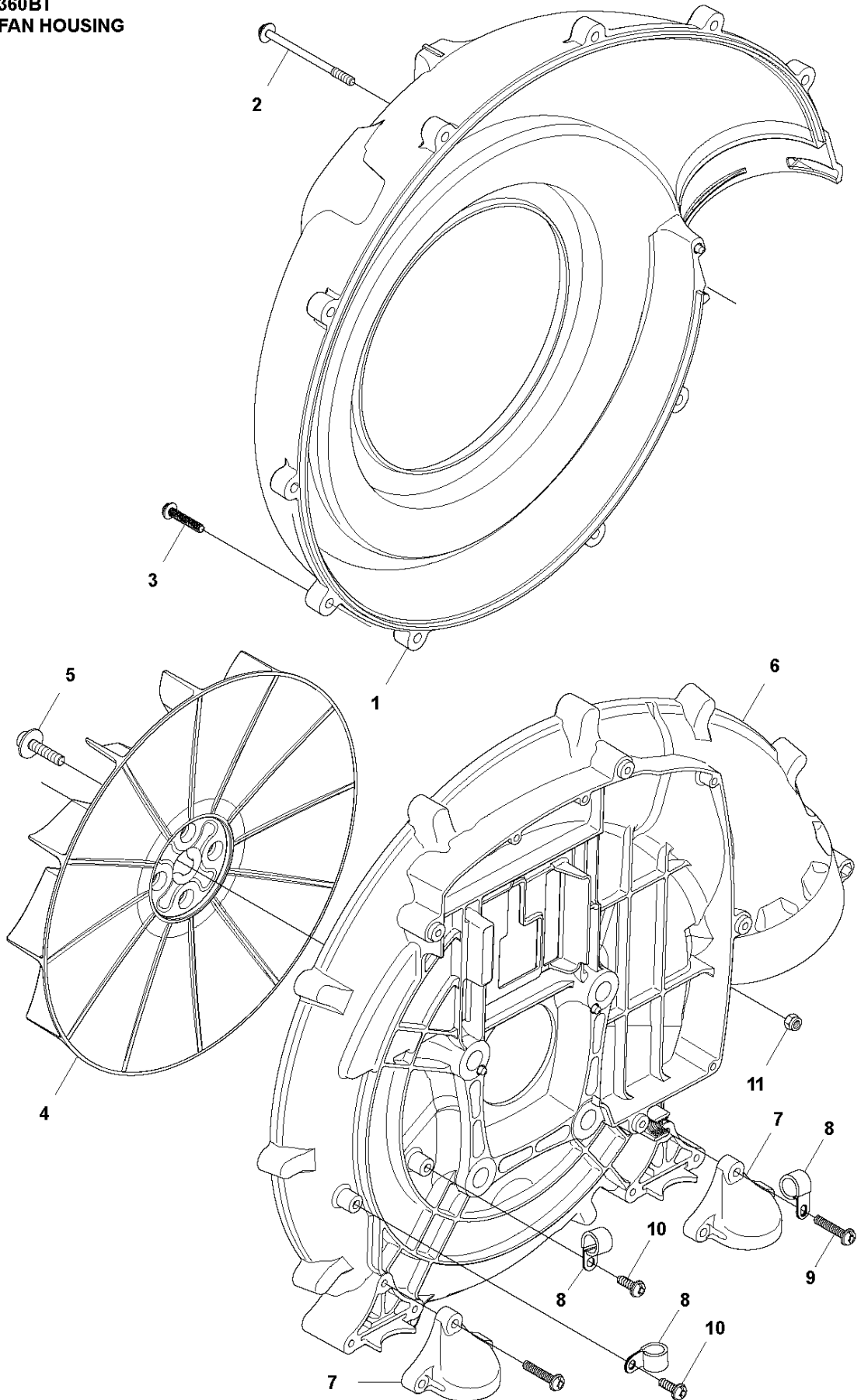



Ref	Part No	Description	Remark	QTY KIT
1	576 70 29-01	VOLUTE		1
2	544 26 46-01	SCREW		2
3	512 84 81-01	SCREW		10
4	577 14 48-01	FAN		1
5	576 56 16-01	BOLT		4
6	576 70 28-01	VOLUTE		1
7	576 57 94-01	BRACKET		2
8	504 12 23-01	CLAMP		3
9	512 84 81-01	SCREW		6
10	512 84 79-01	SCREW		2
11	514 18 39-01	NUT		2

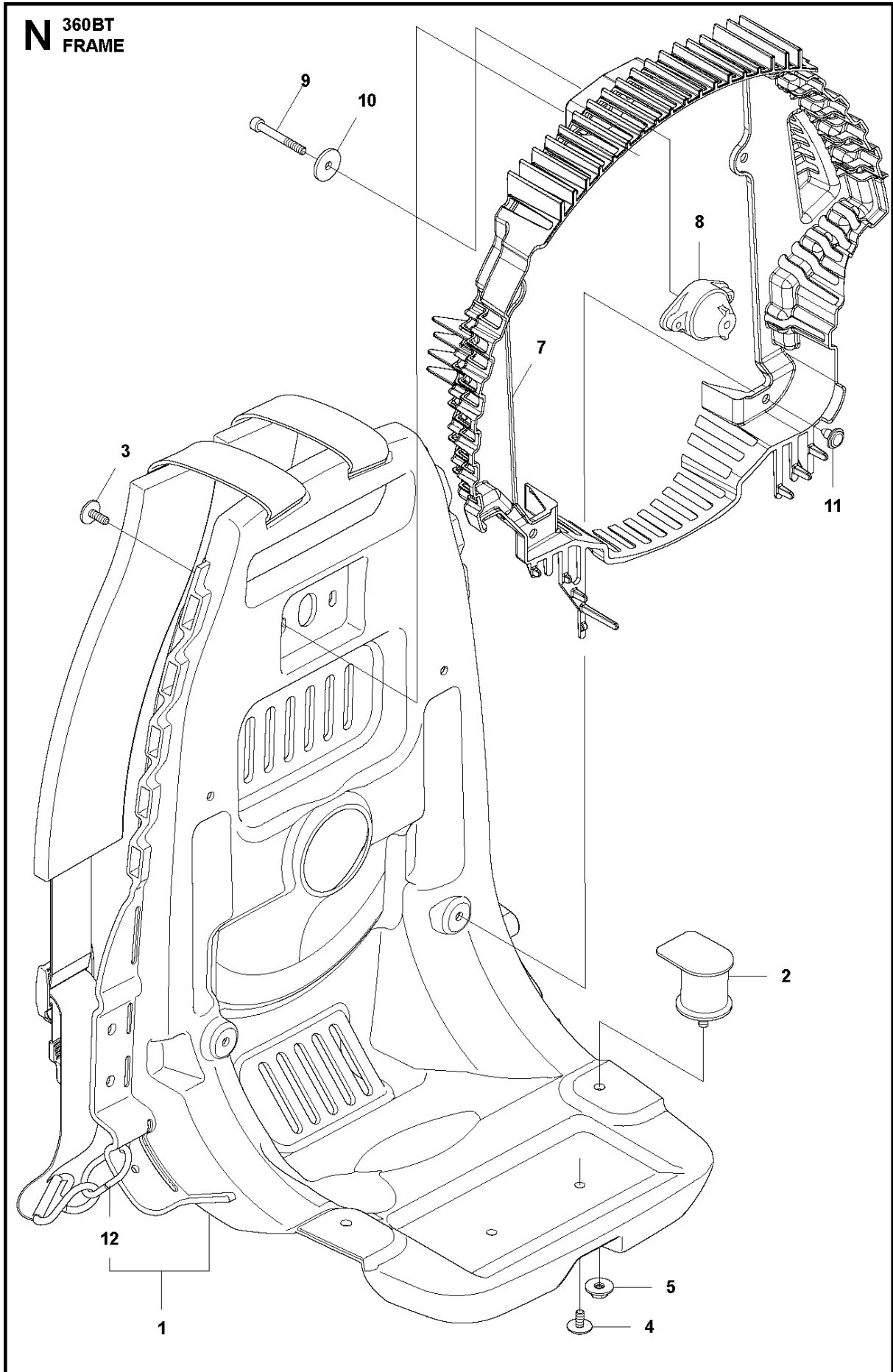

Ref	Part No	Description	Remark	QTY	KIT
1	577 26 12-01	FRAME		1	
2	576 56 22-01	DAMPER		2	
3	544 27 08-01	SCREW		2	
4	577 62 88-01	SCREW		2	
5	513 66 75-01	NUT		2	
7	579 65 95-02	NET		1	
8	513 66 67-01	DAMPER		1	
9	521 51 72-01	BOLT		1	
10	577 35 79-01	WASHER		1	
11	526 24 39-01	CLIP		4	
12	514 33 16-01	RING		2	1

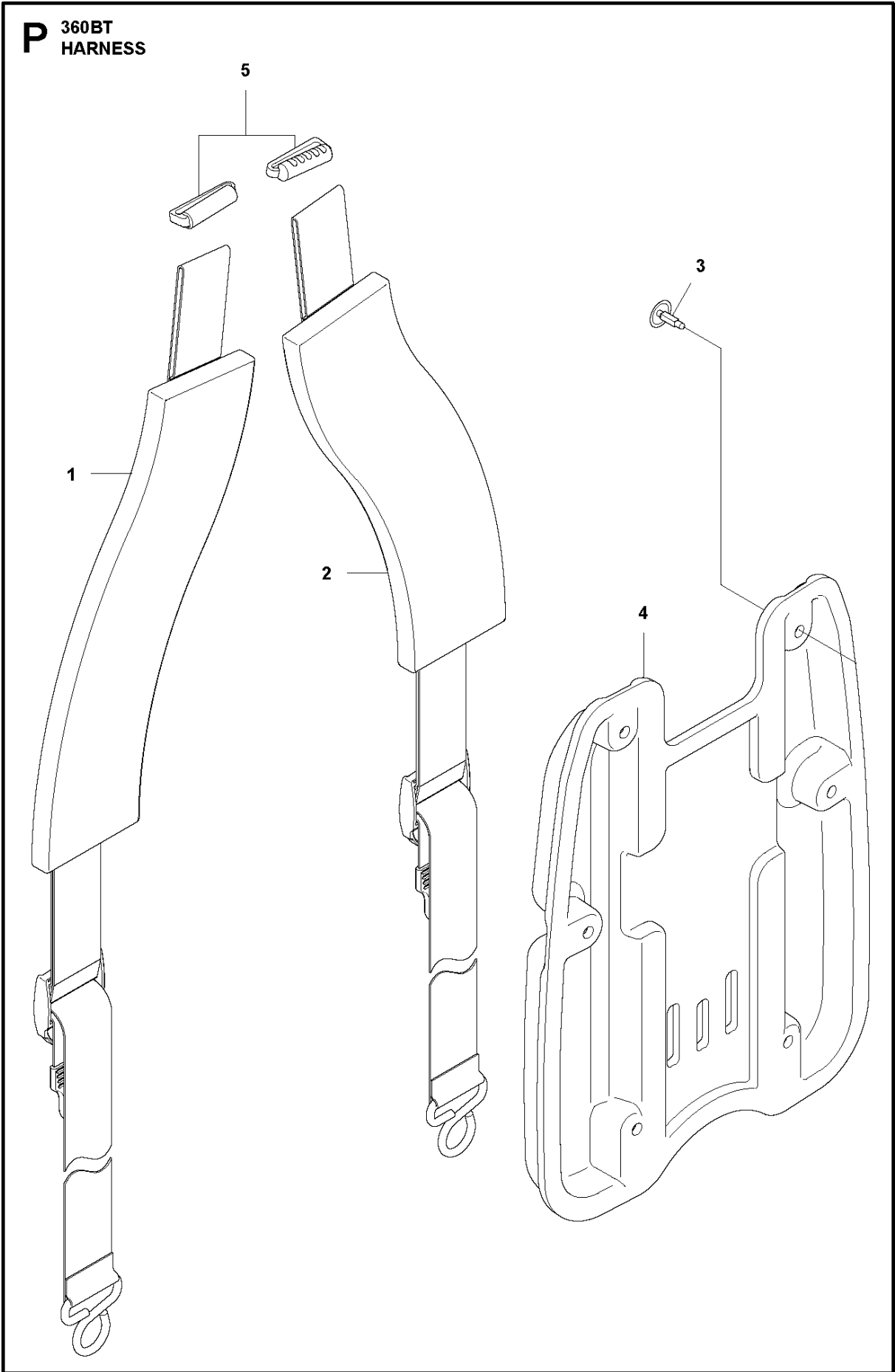

Ref	Part No	Description	Remark	QTY KIT
1	505 18 56-01	BAND		1
2	505 18 55-01	BAND		1
3	526 47 67-01	CLIP		6
4	576 56 20-01	PAD		1
5	544 27 00-01	CLIP		2

**Q** 360BT  
CARBURETOR

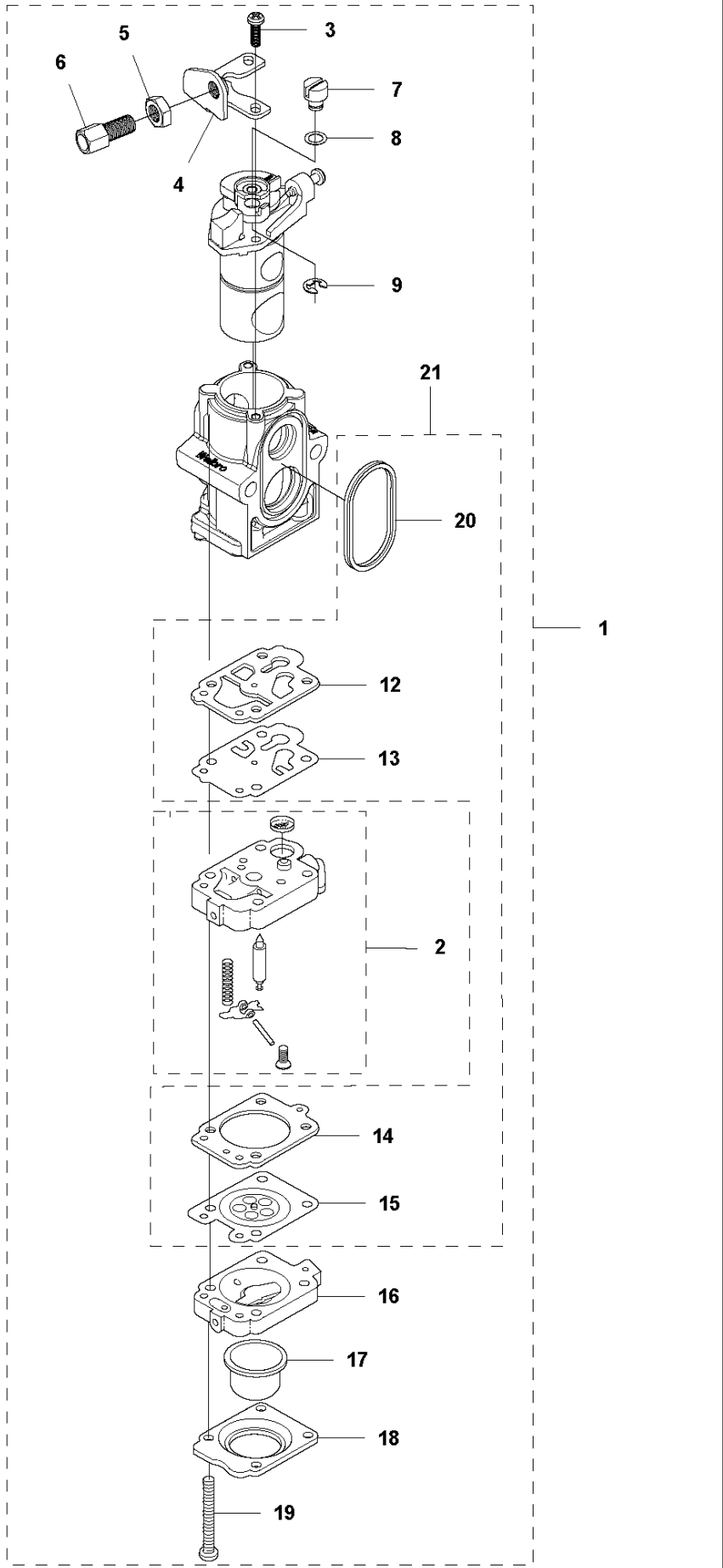

## CARBURETOR

360 BT

Ref	Part No	Description	Remark	QTY	KIT
1	581 15 58-01	CARBURETTOR		1	
2	544 36 35-01	BODY CARBURETTOR		1	1
3	505 30 79-01	SCREW		2	1
4	506 74 60-01	BRACKET		1	1
5	506 61 26-01	NUT		1	1
6	506 74 13-01	SCREW		1	1
7	506 74 12-01	SWIVEL		1	1
8	506 74 61-01	WASHER		1	1
9	506 73 86-01	RETAINER RING		1	1
12	506 74 51-01	GASKET		1	1, 21
13	506 68 98-01	DIAPHRAGM		1	1, 21
14	506 74 08-01	GASKET		1	1, 21
15	505 30 68-01	DIAPHRAGM		1	1, 21
16	506 74 09-01	BODY		1	1
17	505 30 67-01	PUMP		1	1
18	506 74 10-01	COVER		1	1
19	506 74 11-01	SCREW		4	1
20	521 63 15-01	RING		1	1, 21
21	511 45 95-01	GASKET KIT		1	

**R** 360BT  
ACCESSORIES

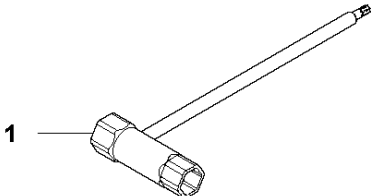

2

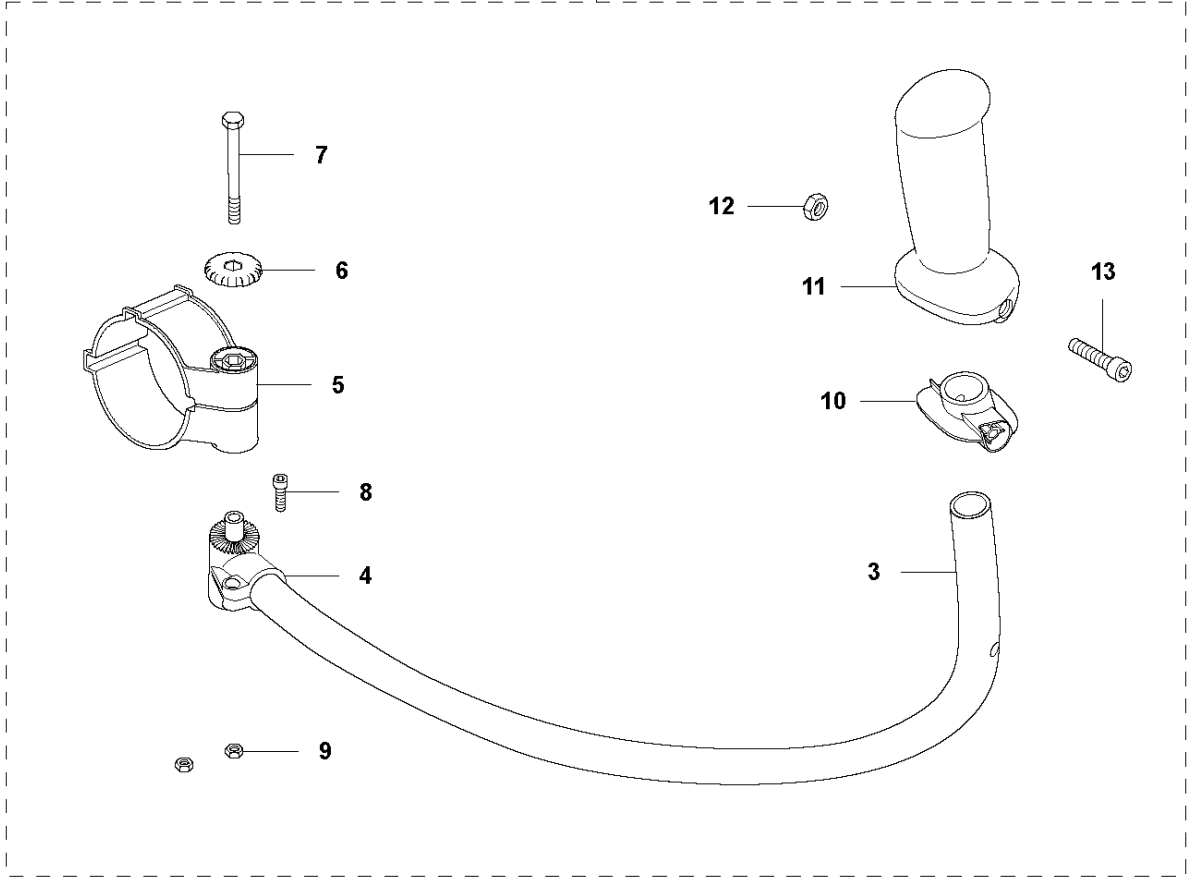



## ACCESSORIES

360 BT

Ref	Part No	Description	Remark	QTY	KIT
1	521 53 30-01	SOCKET		1	
2	544 40 00-01	HANDLEBAR ASSY		1	
3	537 24 13-01	HANDLEBAR		1	2
4	537 29 29-01	BRACKET		1	2
5	577 31 77-01	HANDLE HOLDER		1	2
6	502 20 40-01	KNOB		1	2
7	725 23 47-51	SCREW EHHM		1	2
8	725 53 25-55	SCREW IHSCM		1	2
9	731 23 14-01	HEXAGON NUT		2	2
10	537 17 29-01	COVER		1	2
11	537 17 28-01	HANDLE		1	2
12	731 23 14-01	HEXAGON NUT		1	2
13	503 20 02-45	SCREW IHSCFM		1	2